



INTORQ

setting the standard

Electromagnetic braking systems

for lift applications

www.intorq.com

We set the standards

INTORQ stands for reliable brake solutions with the highest product standards. Whether in crane and lift systems, wind turbines, industrial trucks or brake motors, we offer you the right solutions for your drive – individual and safe.

The INTORQ module system with its broad range of different versions has set standards worldwide. We have a global presence, with sites in Shanghai, Atlanta and Pune. Our sales network and service are available for you locally, all across the world.

INTORQ at a glance

- Sales volume >55 million euros per year
- 1,000,000 units per year
- 13,000 square metres of production space
- 285 employees
- Market leader with 63 sales partners in 49 countries



INTORQ quality worldwide

We manufacture our products with the same processes and the same quality at all INTORQ sites. The basis for this is provided by our international production network. We can react flexibly in production thanks to our versatile assembly structure.

INTORQ test laboratory

The main focus in our development work is on the quality and safety of our brakes. Our products are thoroughly tested, and function-relevant values are continuously documented.

In Germany, we have the honour of being one of only three firms worldwide that are allowed to carry out online tests on behalf of the TÜV-SÜD/ Deutschland inspection agency.

INTORQ logistics certified

Our approval as a “Known Consignor” carries the number DE/KC/0898-01. Our freight consignments now do not have to be checked at airports, so they can be delivered more quickly and more cost-effectively.

INTORQ is an AEO

An AEO is an authorised economic operator in the European Union who has been checked by the Customs Office and consequently enjoys certain privileges (simplified customs procedures, preferential treatment etc.). The AEO programme is recognised by numerous other countries (for example, the USA and China).

Safety when you need it: Braking systems for lift applications

Safety takes top priority in brake systems for lifts. We offer you specific solutions for different drive concepts in lift technology.

Whether with geared motors or direct drives – our brake systems are tailored exactly to meet your needs.

The most important properties of INTORQ braking systems for lift applications:

- Redundant braking systems
- Stable braking torque, even with friction surfaces at high temperatures
- Stable, long-term noise reduction

INTORQ BFK464-R

Dual-circuit spring-applied brake

page 4

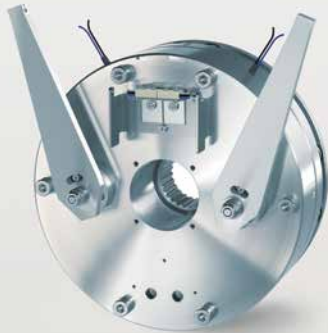

INTORQ BFK455

Double spring-applied brake

page 7



NEW
Size 25

INTORQ BFK454

Dual-circuit spring-applied brake

page 8



INTORQ BFK458

Double spring-applied brake

page 9



INTORQ BFK457

Double spring-applied brake

page 10





Power

... needs control. Discover new perspectives:
The BFK464-R is the INTORQ brake for your
lift applications – smaller, stronger, and more compact.
It is worth comparing ...

We set the standards – standards you can rely on.

INTORQ BFK464-R

Dual circuit spring-applied brake

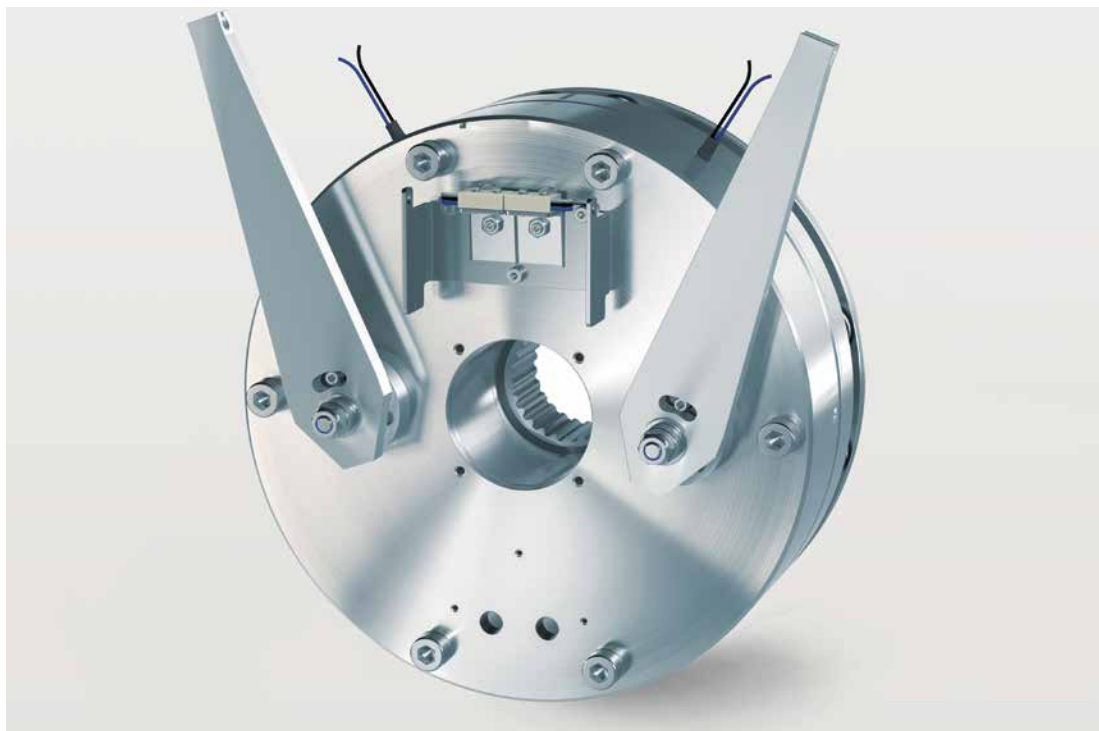

The compact and powerful dual-circuit spring-applied BFK464-R brake can achieve a high braking torque within a small installation space. The brake redundancy necessary for use in lift systems is achieved with a split armature plate and two independent coil circuits.

Other features of the BFK464-R are fast operating times and sophisticated noise reduction.

The tried-and-tested function monitoring by mechanical or inductive sensors as well as an optional wear detection system enables safe integration into drive control.

➤ *Measurements and other information about the BFK464-R can be found on the next page.*

FEATURES

- Seven construction sizes with braking torques up to 2x1200 Nm
- Stable braking torques on high-temperature contact surfaces
- Low-noise switching through stable, long-term, maintenance-free noise reduction
- Function monitoring by microswitch, mechanical or inductive
- Optional wear detection by microswitch, mechanical
- Cost-effective control by bridge/half-wave rectifier as standard, other common types of control are also possible
- Rotor/drive-shaft connection by direct tothing or hub
- Manual release is optionally available and can be retrofitted
- Supplied with seal
- Type-tested in accordance with EN81-20/50-2014

INTORQ BFK464-R

Dual circuit spring-applied brake

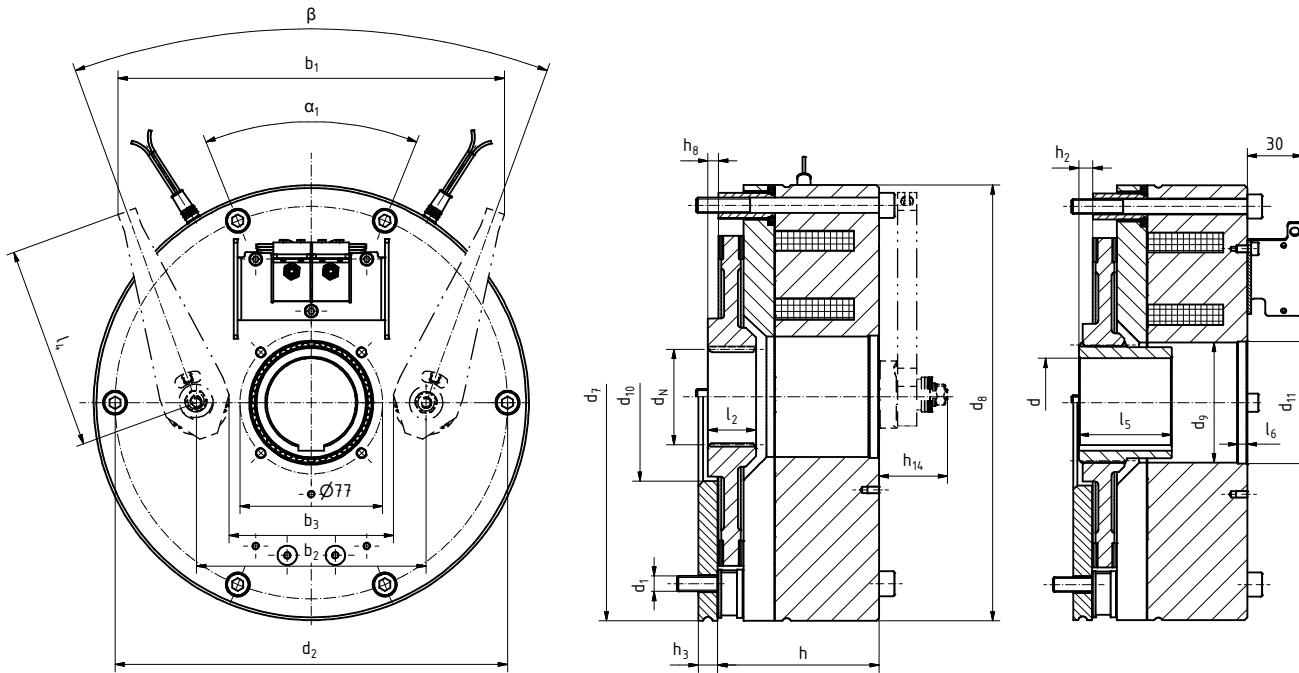

Size		17		18		19		20		22		25		28	
Voltage Switching/Holding ¹⁾	[V]	103/103	205/103	103/103	205/103	103/103	205/103	103/103	205/103	103/103	205/103	103/103	205/103	103/103	205/103
Overexcitation	[-]	without	with	without	with	without	with	without	with	without	with	without	with	without	with
Max. rated torque ²⁾	[Nm]	2x75	2x150	2x170	2x280	2x210	2x350	2x280	2x450	2x360	2x600	2x540	2x900	2x720	2x1200
Electrical power ³⁾	[W]	2x75	2x200	2x88	2x230	2x95	2x245	2x100	2x270	2x110	2x285	2x120	2x300	2x160	2x400
Max. speed of rotation ⁴⁾	[r/min]	900		900		900		900		750		700	600	600	500
Dimensions brake	d ₁	6xM8		6xM8		6xM10		6xM10		6xM10		6xM12		6xM16	
	d ₂	176		212		220		233		252		282		314	
	d ₈	197		235		247		260		280		315		348	
	d ₉ ^{+0,1}	45		65		65		65		65		65		65	
	d ₁₀	90		90		90		90		120		120		120 (150) ⁶⁾	
	d ₁₁	65		66		66		66		66		66		66	
	h	73,9		83,4		85,4		90,4		90,4		93,4		102,5	
	l ₆	15		5		5		5		5		5		5	
Dimensions gear teeth	alpha ₁	44°		44°		44°		40°		40°		44°		44°	
	l ₂	22,5		25		28		35		30		42		55	
	h ₈	5,5		5,5		6,7		11		12		16,5		14,5	
Dimensions hub	d _N ⁵⁾	N45x1,25x34		N55x2x26		N55x2x26		N55x2x26		N70x2x34		N70x2x34		N70x2x34	
	h ₂	7,5		7,5		8,7		14		14		18,5		16,5	
Dimensions flange	l ₅	25		40		45		55		45		70		60	
	d ^{H7}	30		35		40		40		50		50		60	
Dimensions hand-release	d ₇	197		235		247		260		280		315		348	
	h ₃	10		10		10		11		11		12,5		12,5	
Dimensions hand-release	b ₁	208		212		280		280		345		365		385	
	b ₂	120		124		146		146		150		170		190	
	b ₃	80		84		98		98		102		122		142	
	l ₄	110		110		180		180		270		270		270	
	h ₁₄ ^{+2,5}	38,5		35,5		46,6		43,6		45,6		45,6		53,5	
beta	40°		40°		40°		40°		40°		40°		40°		

¹⁾ Additional voltage values and overexcitations on request

²⁾ M_K: Brake rated torque in Nm in relation to n = 100 r/min

³⁾ Electrical power at 20°C; at overexcitation (overflux) the releasing power is specified

⁴⁾ higher speed of rotation on request

⁵⁾ Toothed shaft according DIN 5480

⁶⁾ Valid for design with hub

Additional sizes and braking torques on request

Dimensions in mm

More technical information can be found in the operating instructions

INTORQ BFK455-28

Double spring-applied brake



The powerful double spring-applied brake BFK455-28 is a redundant braking system intended for use in direct drives. Due to its flat design this brake can be easily integrated in existing drive solutions.

Characteristics

- Braking torques of up to 2x2065 Nm
- Stable braking torque even with high-temperature contact surfaces
- Noise reduction with long-term stability
- Flat design
- Cost optimised control due to bridge/half-wave rectifier (necessary)
- Safe operation by monitoring the brake circuits with micro switch
- Manual release optional
- Type tested according to EN81-20/50-2014

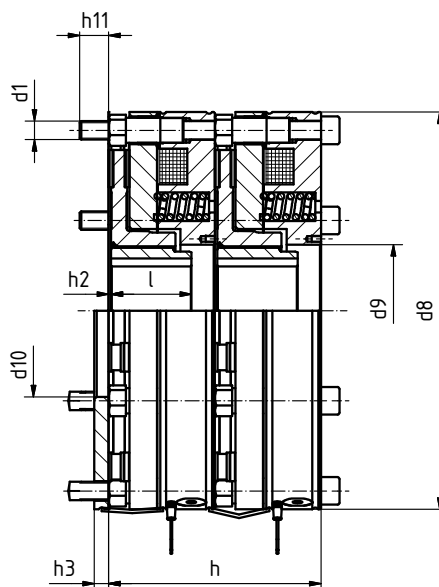
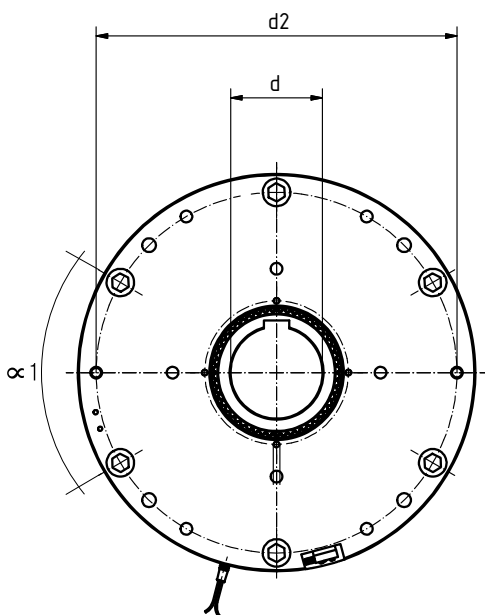

Size	M_K	P_{20} Switch	Hold	$d^{H7/l}$ (bore diameter/length) Standard 1)	d1	d2	d8	d9 ^{H9}	d10	h	h2	h3	h11	α 1
25	2x1200	2x236	2x59	(50/70) ²⁾	6xM12	282	315	117	120	167	1	12.5	21	44
25	2x1500	2x425	2x106	(50/70) ²⁾	6xM12	282	315	117	120	167	1	12.5	21	44
28	2x1200	2x434	2x108.5	(55/85), (60/50), (65/50)	6xM16	314	346	115	150	185	3.7	12.5	25	60
28	2x1800	2x434	2x108.5	(70/70), (80/70)	6xM16	314	346	115	150	185	2	12.5	25	60
28	2x2065	2x434	2x108.5	(80/70)	6xM16	314	346	115	150	185	2	12.5	25	60

■ Additional sizes and braking torques on request

■ M_K : Brake rated torque in Nm in relation to $n = 100$ r/min

■ P_{20} : Coil power at 20 °C in W

■ ¹⁾ Standard keyway according to DIN 6885/1-P9

■ ²⁾ Rotor preferably mounted directly on toothed shaft

■ Angle dimensions in °

■ Dimensions in mm

■ More technical information can be found in the operating instructions

INTORQ BFK454

Dual circuit spring-applied brake

The dual circuit spring-applied brake BFK454 complies Directive 2014/33/EU and EN-81 for lift systems. The dual-circuit braking system is achieved by splitting the armature plate into two segments, the spring force for generating the braking torque acts

- 80% directly on the front armature plate and
- 20% indirectly via the rear armature plate

Characteristics

- Braking torques of up to 400 Nm
- Small construction volume
- Easy adjustment (reduction) of braking torque via the central adjustment ring
- Simple maintenance and inspection of dual-circuit function
- No division of friction surface



INTORQ 155-1

 E318895

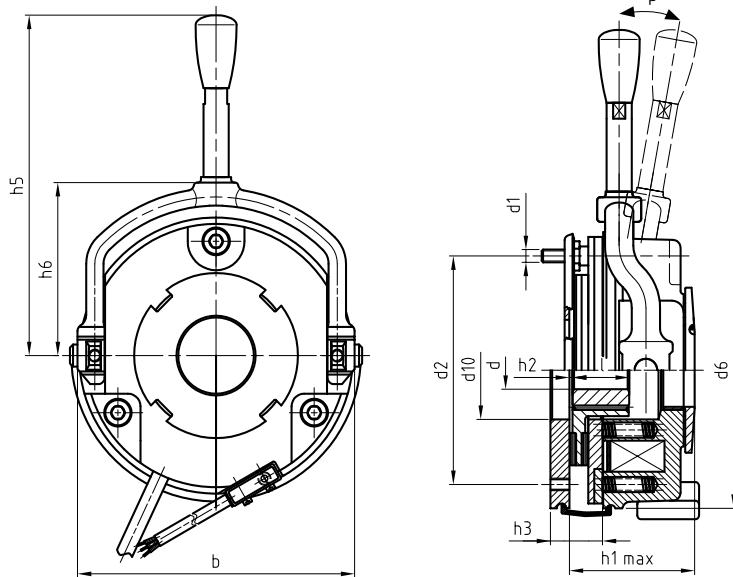

Size	M_K	P_{20}	b	d_{J7} pre. 1)	d_{H7} max. 2)	d1	d2	d6	d10	h1 max.	h3	h5	h6	l	β
10	15	33	132	10	20	3xM6	112	130	45	60,1	9	134	73,8	20	9°
12	30	40	152	14	25	3xM6	132	150	52	68,5	9	163,5	85	25	10°
14	60	53	169	14	30	3xM8	145	165	55	79,5	11	195,5	98	30	9°
16	90	56	194,5	15	38*	3xM8	170	190	70	87,5	11	240	113	30	10°
18	150	85	222	20	45	6xM8	196	217	77	103	11	347	124	35	9°
20	200	100	258	25	50	6xM10	230	254	90	119	11	418	146	40	10°
25	400	110	302	30	70	6xM10	278	302	120	130	12,5	504	170	50	10°

■ M_K : Brake rated torque in Nm in relation to $n = 100$ r/min

■ P_{20} : Coil power at 20 °C in W

■ ¹⁾ Predrilled, without keyway

■ ²⁾ Standard keyway according to DIN 6885/1-P9

*Keyway according to DIN 6885/3-P9

■ Dimensions in mm

■ More technical information can be found in the operating instructions.

INTORQ BFK458

Double spring-applied brake



Double spring-applied brakes of the BFK458 series are suitable for lifts. The required redundant braking system is achieved by using individual components of the BFK458.

Characteristics

- ▮ Braking torques of up to 2x400 Nm
- ▮ Noise-reduced (optional)
- ▮ Modular structure
- ▮ Simple mounting using connection flange
- ▮ Manual release with “one-hand-operation”

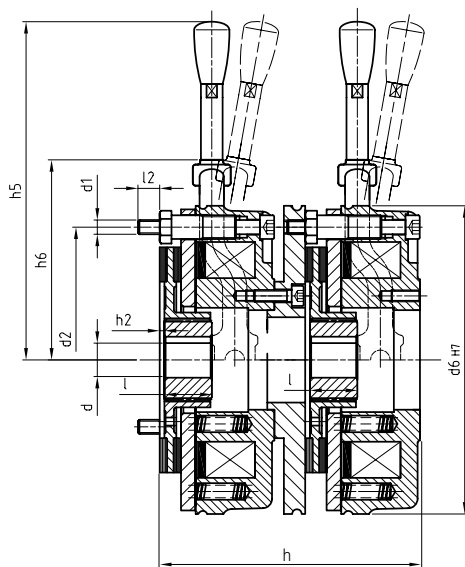

Size	M_K	P_{20}	$d \overset{J^1}{pre. 1)}$	$d \overset{H7}{max. 2)}$	d_1	d_2	d_6	h	h_5	h_6	l	l_2
06	2x4	2x20	10	15	3xM4	72	87	84,6	107	56,3	18	8,7
08	2x8	2x25	10	20	3xM5	90	105	97,6	118	65	20	9,8
10	2x16	2x30	10	20	3xM6	112	130	109,8	134	77,8	20	12,7
12	2x32	2x40	14	25	3xM6	132	150	125,8	163,5	88,5	25	13,1
14	2x60	2x50	14	30	3xM8	145	165	148	195,5	101,5	30	13,1
16	2x80	2x55	15	38*	3xM8	170	190	165	240	116	30	16,4
18	2x150	2x85	20	45	6xM8	196	217	186,2	347	128,5	35	17,5
20	2x260	2x100	25	50	6xM10	230	254	215,2	418	149,5	40	17,8
25	2x400	2x110	30	70	6xM10	278	302	236,4	504	175,5	50	21,5

▮ Additional sizes and braking torques on request

▮ M_K : Brake rated torque in Nm in relation to $n = 100$ r/min

▮ P_{20} : Coil power at 20 °C in W

▮ ¹⁾ Predrilled, without keyway

▮ ²⁾ Standard keyway according to DIN 6885/1-P9

*Keyway according to DIN 6885/3-P9

▮ Dimensions in mm

▮ More technical information can be found in the operating instructions

INTORQ BFK457

Double spring-applied brake

Double spring-applied brakes BFK457 fulfill the high demands on redundant braking systems in lifts. The switching noise is minimised by special arrangement of damping elements and achieves values of <50 dbA.

Characteristics

- Braking torques up to 2x80 Nm
- Noise-reduced < 50 dbA
(armature plate and rotor)
- Modular structure
- Easy installation
- Manual release with “one-hand-operation”

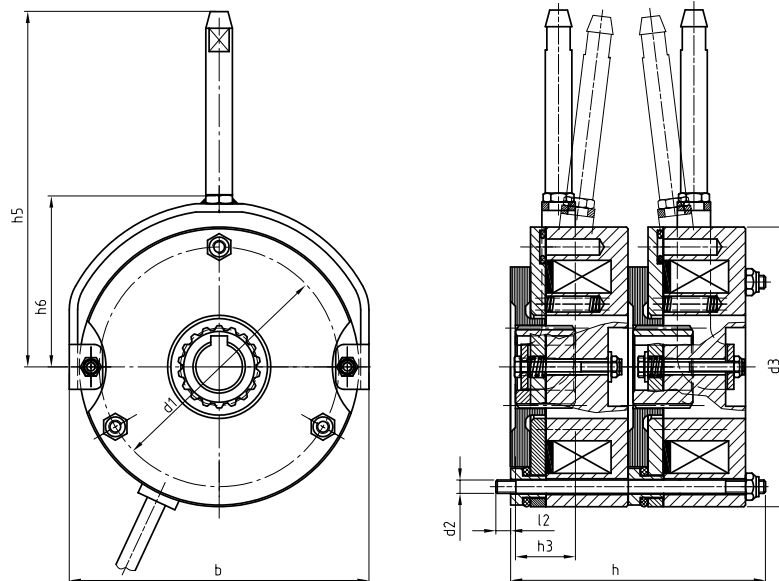

Size	M _K	P ₂₀	b	d ^{J7} pre. ¹⁾	d ^{H7} max. ²⁾	d1	d2	d3	h	h3	h5	h6	l2
06	2x4	20	90	10	15	72	3xM4	84	75,5	18	109	54	6
08	2x8	25	108	10	20	90	3xM5	102	90,5	20	121,7	62	9
10	2x16	30	137	10	20	112	3xM6	130	102,9	20	147	84	11
12	2x32	40	157	14	25	132	3xM6	150	114,7	25	166	93	11
14	2x60	50	174	14	30	145	3xM8	165	140,5	30	186	106	14
16	2x80	55	203	15	38*	170	3xM8	190	153,1	30	230	120,5	14

■ Additional sizes and braking torques on request

■ M_K: Brake rated torque in Nm in relation to n = 100 r/min

■ P₂₀: Coil power at 20 °C in W

■ ¹⁾ Pre-drilled, without keyway

■ ²⁾ Standard keyway according to DIN 6885/1-P9

* Keyway according to DIN 6885/3-P9

■ Dimensions in mm

■ More technical information can be found in the operating instructions

Service and sales, worldwide

We are available to our customers at all times and in all locations. Major customers and projects are supported directly by our Key Account Sales Team at our HQ in Aerzen (Germany) or by our locations in Shanghai (China), Atlanta (USA) and Pune (India).

In addition to this, we work with a global network of local trading partners and cooperate with Lenze's global sales organisation. Please send service requests directly to your local sales partner or to our HQ in Aerzen, Germany:

E-mail service@intorq.de

Tel: +49 5154 70534-444

Fax: +49 5154 70534-200

› You can find more information on our products, as well as catalogues and operating instructions available for download, on our website at www.intorq.com





INTORQ GmbH & Co. KG

Germany

Postfach 1103, D-31849 Aerzen, Germany
Wülmser Weg 5, D-31855 Aerzen, Germany

Tel, Head office: +49 5154 70534-0
Tel, Sales department: +49 5154 70534-222
Fax: +49 5154 70534-200
E-mail info@intorq.de

INTORQ (Shanghai) CO., LTD

China

No. 600, Xin Yuan Nan Road,
Building No. 6 / Zone B
Nicheng town, Pudong
Shanghai, China 201306

Tel: +86 21 20363-810
Fax: +86 21 20363-805
E-mail info@cn.intorq.com

INTORQ US INC.

USA

300 Lake Ridge Drive SE
Smyrna, GA 30082, USA

Tel: +1 678 236-0555
Fax: +1 678 309-1157
E-mail info@us.intorq.com

INTORQ India Pvt. Ltd.

India

Plot No. E-7/3, Chakan
Industrial Area, Phase 3,
Nighoje, Taluka-Khed,
Pune, 410501 Maharashtra

Tel: +91 21 3562-5500
E-mail info@intorq.in